



(click to enlarge)

**Clear Anodized
(Open View)**

(click to enlarge)

**Clear Anodized
(Assembled View)**

(click to enlarge)

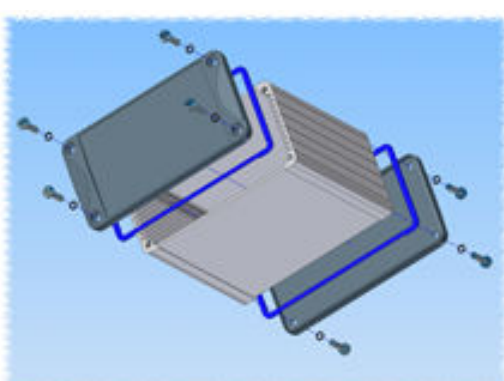
**Flanged Version
Clear Anodized
(Assembled View)**

(click to enlarge)



















Key Features:

- Watertight - [heavy duty extruded enclosures](#) designed to house P.C. boards or for equipment interfacing.
- Sized for standard Eurocards.
- P.C. boards mount horizontally by sliding into internal slots extruded into the enclosure body.
- Rugged body constructed from one piece, extruded aluminum with a minimum thickness of .06" (1.5 mm).
- Extruded aluminum body includes a recessed area for labels or membrane keypad.
- End panels are rugged - yet easy to machine - diecast aluminum with full perimeter self-adhesive gaskets.
- Designed to meet IP 65 ratings.
- Choice of two versions - end panels without flange or with flange (for shelf or wall mounting).

Includes:

- Two diecast aluminum end panels - painted in a durable, black satin powder paint.
- Extruded, aluminum body (choice of either clear anodized or black powder paint finish).
- Two closed cell polyethylene foam - end plate gaskets & rubber "O" rings for assembly screws.
- All hardware and self-adhesive feet.





REGULAR FRONT & BACK END PANELS (NO MOUNTING FLANGE)

| Part Number | Extruded Body Color | Reader File |  Drawing File Size | AutoCAD .dwg Files (zipped) | .zip File Size | 3D Solid Model .igs & .stp files (zipped) | 3D .zip File Size | Units | Length | Width | Height |
|--|---------------------|---|---|---|----------------|---|-------------------|--------|--------|-------|--------|
| 1457C801 1457C801BK | Clear Black |  | 274K |  | 238K |  | 258K | Inches | 3.15 | 2.32 | 1.21 |
| | | | | | | | | mm | 80 | 59 | 30.9 |
| 1457C1201 1457C1201BK | Clear Black |  | 282K |  | 248K |  | 258K | Inches | 4.73 | 2.32 | 1.21 |
| | | | | | | | | mm | 120 | 59 | 30.9 |
| 1457K1201 1457K1201BK | Clear Black |  | 458K |  | 314K |  | 437K | Inches | 4.73 | 3.30 | 1.73 |
| | | | | | | | | mm | 120 | 84 | 44.1 |
| 1457K1601 1457K1601BK | Clear Black |  | 451K |  | 311K |  | 437K | Inches | 6.30 | 3.30 | 1.73 |
| | | | | | | | | mm | 160 | 84 | 44.1 |
| 1457N1201 1457N1201BK | Clear Black |  | 436K |  | 342K |  | 300K | Inches | 4.73 | 4.09 | 2.15 |
| | | | | | | | | mm | 120 | 104 | 54.6 |
| 1457N1601 1457N1601BK | Clear Black |  | 437K |  | 338K |  | 300K | Inches | 6.30 | 4.09 | 2.15 |
| | | | | | | | | mm | 160 | 104 | 54.6 |



(click to enlarge)

**Flanged Version
Clear Anodized
(Bottom View)**
FLANGED VERSION

| Part Number | Extruded Body Color | Reader File |  Drawing File Size | AutoCAD .dwg Files (zipped) | .zip File Size | 3D Solid Model .igs & .stp files (zipped) | 3D .zip File Size | Units | Length | Width | Height |
|--------------------------------------|---------------------|---|---|---|----------------|---|-------------------|--------|--------|-------|--------|
| 1457C802 1457C802BK | Clear Black |  | 286K |  | 259K |  | 280K | Inches | 3.15 | 2.32 | 1.21 |
| | | | | | | | | mm | 80 | 59 | 30.9 |

| | | | | | | | | | | | |
|--|-------|---|------|---|------|--|------|--------|------|------|------|
| 1457C1202 1457C1202BK | Clear |  | 284K |  | 260K |  | 280K | Inches | 4.73 | 2.32 | 1.21 |
| | Black | | | | | | | mm | 120 | 59 | 30.9 |
| 1457K1202 1457K1202BK | Clear |  | 461K |  | 310K |  | 479K | Inches | 4.73 | 3.30 | 1.73 |
| | Black | | | | | | | mm | 120 | 84 | 44.1 |
| 1457K1602 1457K1602BK | Clear |  | 457K |  | 318K |  | 479K | Inches | 6.30 | 3.30 | 1.73 |
| | Black | | | | | | | mm | 160 | 84 | 44.1 |
| 1457N1202 1457N1202BK | Clear |  | 454K |  | 341K |  | 330K | Inches | 4.73 | 4.09 | 2.15 |
| | Black | | | | | | | mm | 120 | 104 | 54.6 |
| 1457N1602 1457N1602BK | Clear |  | 449K |  | 336K |  | 330K | Inches | 6.30 | 4.09 | 2.15 |
| | Black | | | | | | | mm | 160 | 104 | 54.6 |

Color Options:



(click to enlarge)

- Choose either clear anodized (left) finish or black powder paint (right).
- Note that the diecast aluminum front & back panels are both finished in black powder paint.

Heavy Duty:

DESIGNED FOR TOUGH ENVIRONMENTS !



(click to enlarge)



(click to enlarge)

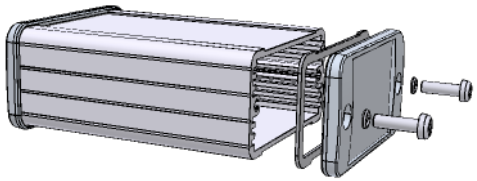
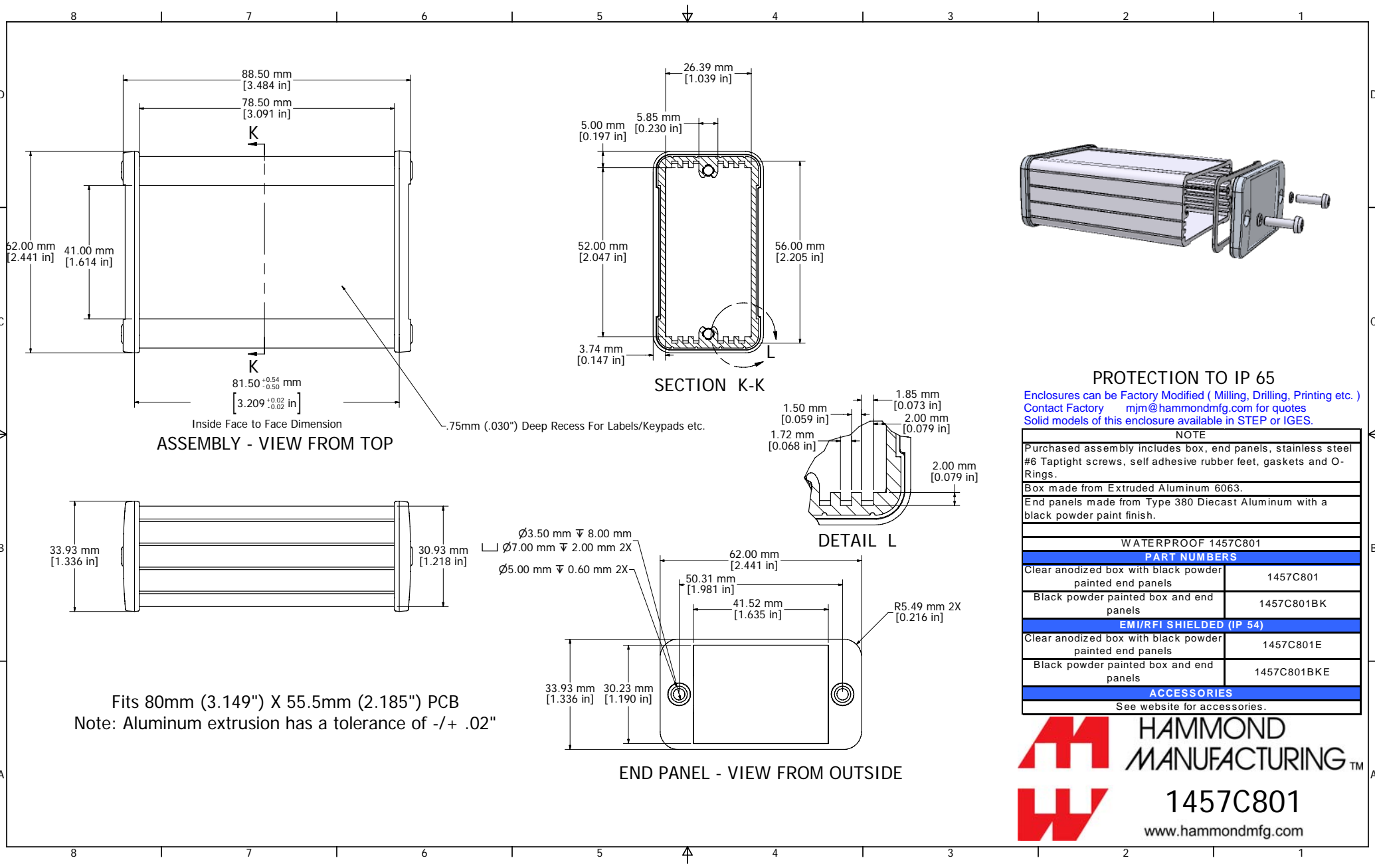

PROTECTION TO IP 65

Enclosures can be Factory Modified (Milling, Drilling, Printing etc.)
Contact Factory mjm@hammondmfg.com for quotes
Solid models of this enclosure available in STEP or IGES.

| NOTE | |
|--|-------------|
| Purchased assembly includes box, end panels, stainless steel #6 Taptight screws, self adhesive rubber feet, gaskets and O-Rings. | |
| Box made from Extruded Aluminum 6063. | |
| End panels made from Type 380 Diecast Aluminum with a black powder paint finish. | |
| WATERPROOF 1457C801 | |
| PART NUMBERS | |
| Clear anodized box with black powder painted end panels | 1457C801 |
| Black powder painted box and end panels | 1457C801BK |
| EMI/RFI SHIELDED (IP 54) | |
| Clear anodized box with black powder painted end panels | 1457C801E |
| Black powder painted box and end panels | 1457C801BKE |
| ACCESSORIES | |
| See website for accessories. | |

HAMMOND MANUFACTURING™

1457C801

www.hammondmfg.com